

Hartland Locomotive Works

Products

Engines:

Class C 0-4-0	4-4-0 American
Class B 0-4-0	Big John
Class A 0-4-0	2-4-0 Dutchess W/Tender
2-4-4 Forney	“Mighty Mack” Switcher
Rail Motor Car	Interurban
Rail Bus	“Woody” Rail-Car
Line Car	“Woody” Pick-Up
“Sparky” Switcher	Birney Trolley
Mining Engine	2-6-0 Mogul

Starter Sets:

South West	Army Set
------------	----------

Rolling Stock:

Flat Cars	Log Cars (Real Logs)
Gondolas	Box Cars
Caboose	Work Caboose
Long Passenger Coaches, Combos & RPOs	
Short Passenger Coaches & Combos	

Track:

Brass Track	Aluminum Track
Specialty Orders (Call for Details)	



Hartland Locomotive Works

Designed and Manufactured in LaPorte, IN U.S.A.

P.O. Box 1743
LaPorte, IN 46352
Voice (219) 362-8411
Fax (219) 362-7568

Hartland Locomotive Works

Designed and Manufactured in LaPorte, IN U.S.A.

P.O. Box 1743
LaPorte, IN 46352
Voice (219) 362-8411
Fax (219) 362-7568



Disney's Lilly Belle Operation and Warranty Manual

Hartland Locomotive Works thanks you for your purchase. Your Locomotive is an American made product, manufactured in LaPorte, Indiana and is designed to give you years of service. Your Locomotive is not a toy, and is intended for use by adults 18 years of age or older.

Our Pledge to you:

*To bring you the Highest Quality, American Built,
G-scale Products at an Affordable Price.*

Motor and Power Specifications

Your HLW Locomotive is equipped with a 12 V DC precision, industrial-grade motor. The motors are mounted in a weather resistant housing and are intended to be waterproof. We recommend using a 2.5 amp power pack with variable speed control. Avoid using "pulse power" as it will eventually harm your motor.

Locomotive Drive Wheels

Drive wheels require cleaning every time the track is cleaned. Turn the locomotive over and wipe the exposed portion of the drive surface with a cloth. Excessive dirt build-up may require use of a brass bristle brush. Place the locomotive on the track and electrically move the unit approximately 1/3 revolution of the wheels. Repeat the wiping process until the unit is clean.

Caution: Under no circumstances should the locomotive drive wheels be turned by hand. Wheels should be turned electrically, with the locomotive on the track.

Smoke Unit

Your HLW locomotive **does not** have a factory installed smoke unit. It **does** have a switch in the cab and wiring going to the smoke stack such that a smoke unit can be added, should you desire one. Call (219) 362-8411 to order a smoke unit.

Operation: The Smoke Unit power switch is located in the cab of your locomotive. With the unit off (See Fig. 1-A) fill the smoke unit with distillate oil until half full. To turn on, flip the switch toward the white dot. The density of the smoke depends upon the operating voltage. As the distillate oil is used up the density of the smoke will lessen.

HEADLIGHT BULB REPLACEMENT

Your HLW Locomotive comes with a long life direct-wired light that may never need replaced. Should your bulb ever need replaced please contact the HLW Parts and Service Department for parts and instructions.

**Hartland Locomotive Works Parts and Service Dept. phone:
(402) 571-2933 Tuesdays and Thursdays. Call for hours.**

Hartland Locomotive Works Limited Warranty

What This Warranty Covers:

These products are warranted to be free from all defects in material and workmanship in normal intended use for the period of one year from the original date of purchase. Warranty is subject to the following provisions. HLW will, at its option, repair or replace a defective part or unit that is covered by warranty. As a matter of warranty policy, HLW will not refund the customer's purchase price.

What This Warranty Does Not Cover:

Warranty remedies are not available if the product is damaged by misuse, abuse or operations not originally intended for this product.

Commercial use and / or continuous operation: Motor is warranted by the original motor manufacturer for one year or 1000 hours. Please contact HL W at (219) 362-8411 if problems arise.

HLW makes no other warranties expressed or implied, and will not be responsible for any consequential or incidental damages or accidents resulting from the sale or use of this product. Some states do not allow this exclusion or limitation of incidental or coincidental damages, so these limitations may not apply to you.

Obtaining Warranty Service:

Please call HLW at (402) 571-2933 for a return authorization. Products to be repaired should be packaged (preferably in the original carton and packing material) and shipped to:

**Hartland Locomotive Works
8025 Dutch Hall Rd.
Omaha, NE 68122**

COUPLER INSTALLATION

The Tender is shipped with a loop style coupler unattached in a plastic bag. If you wish to install a knuckle style coupler, they are available from your large-scale dealer that will fit our trucks.

Installing the loop coupler:

1. Place hole in Loop Bar (Item 1) over the shank on truck and attach with screw provided (Item 3).
2. Coupler Hook (Item 2) in Loop Bar by placing pin in hole on one side then pressing the opposite pin down till it snaps into the hole completely.

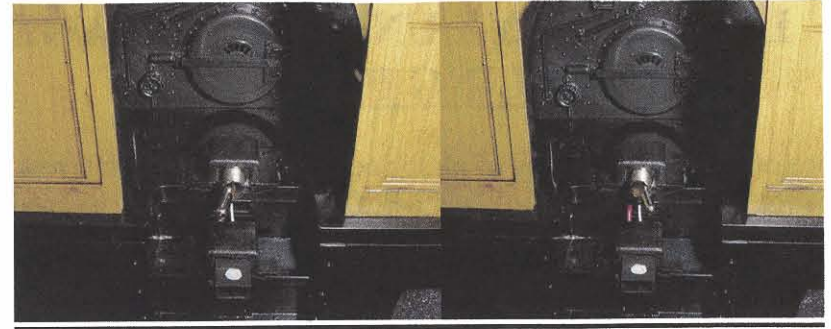
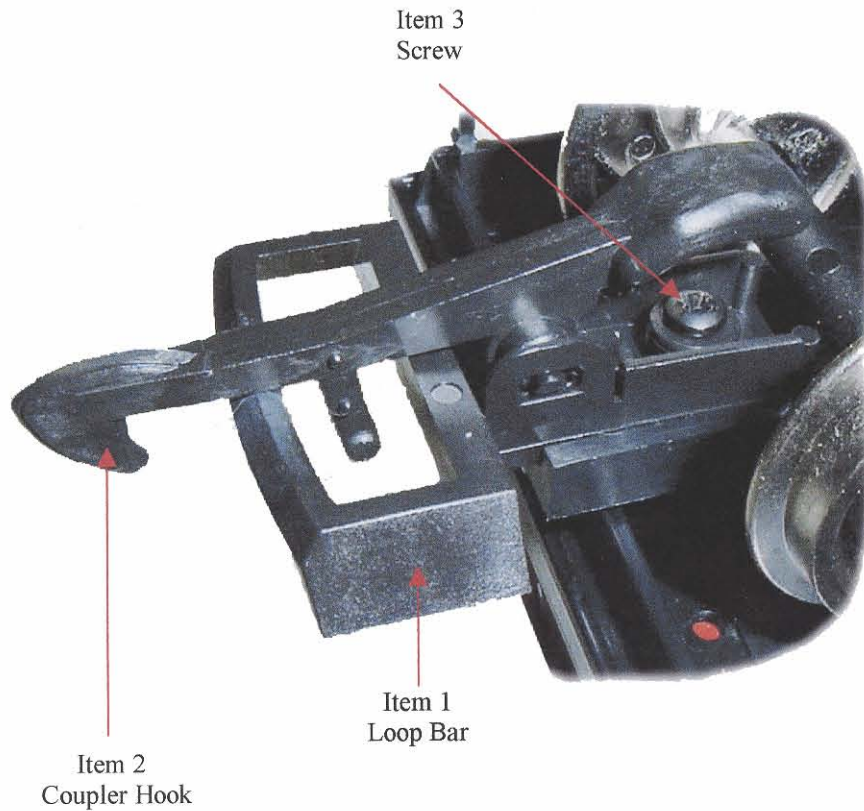

On Position

Fig. 1-A

Off Position

LUBRICATION INSTRUCTIONS

Your Engine, like all fine equipment, will need to be oiled from time to time. To lubricate your engine it is recommended that you use a Pin oiler and only use light oil compatible with plastic that is electrically conductive. When oiling place one drop of oil on each of the locations specified in this manual. Any questions please contact your local dealer or call HLW parts and service dept.

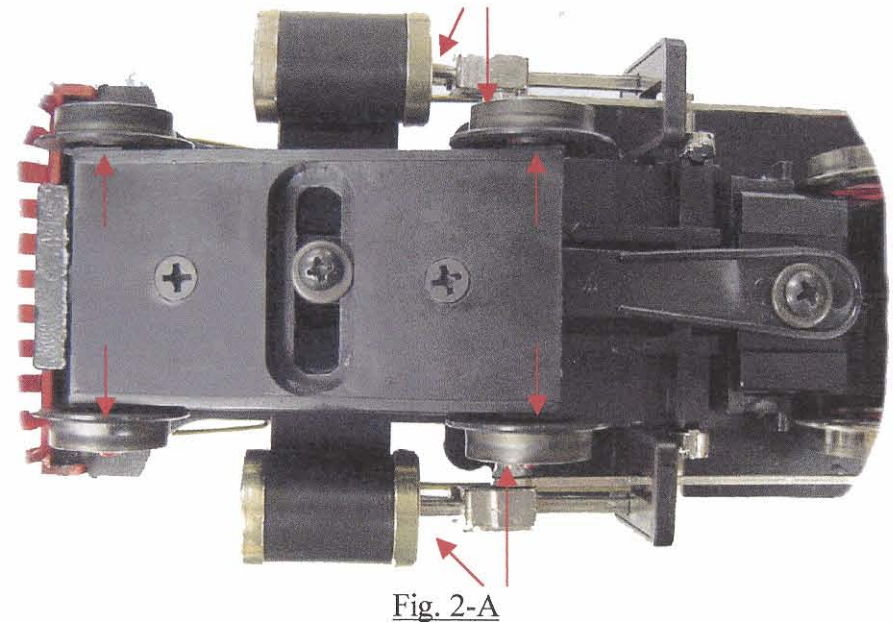

Fig. 2-A

